

B1412、 B1413、 B1418、 B1419 SIDE IMPACT SENSOR

DTC DESCRIPTION

The detecting system for side crash consists of the SRSCM and four Side Impact Sensors (SIS). The SRSCM sets above DTC(s) if it detects that any SIS is defective or there is communication error between any SIS and the SRSCM.

DTC	FAULT DESCRIPTION
B1412	SIDE IMPACT SENSOR [REAR-DRIVER] COMMUNICATION ERROR
B1413	SIDE IMPACT SENSOR [REAR-PASSENGER] COMMUNICATION ERROR
B1418	SIDE IMPACT SENSOR [REAR-DRIVER] DEFECT
B1419	SIDE IMPACT SENSOR [REAR-PASSENGER] DEFECT

DTC DETECTING CONDITION

DTC	Condition	Probable cause
B1412	<ul style="list-style-type: none"> • Open between SIS and SRSCM • Side Impact Sensor (SIS) Malfunction • SRSCM Malfunction 	• Wiring Harness
B1413		• Side Impact Sensor (SIS)
B1418		• Side Impact Sensor (SIS)
B1419		• SRSCM

SCHEMATIC DIAGRAM

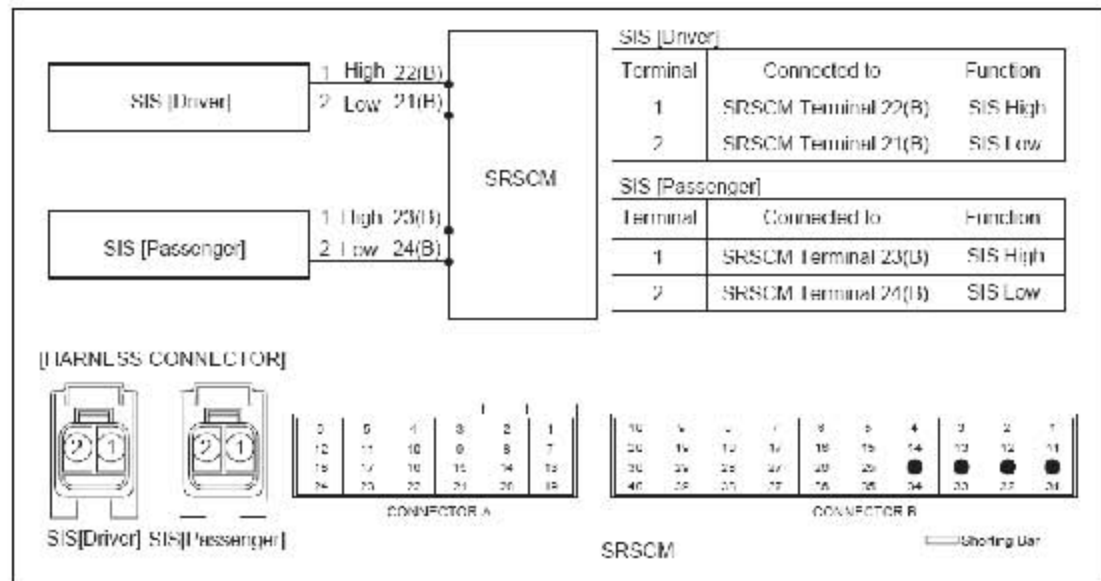

TERMINAL & CONNECTOR INSPECTION

Refer to the DESCRIPTION in this TROUBLESHOOTING section.

INSPECTION PROCEDURE

1). PREPARATION.

Refer to the DESCRIPTION in this TROUBLESHOOTING section.

2). CHECK SIS CIRCUIT

- Measure resistance between the terminal 1 of SIS harness connector and the terminal 22(23) of SRSCM harness connector(B).
- Measure resistance between the terminal 2 of SIS harness connector and the terminal 21(24) of SRSCM harness connector(B).

Specification (resistance) : below 1 Ω

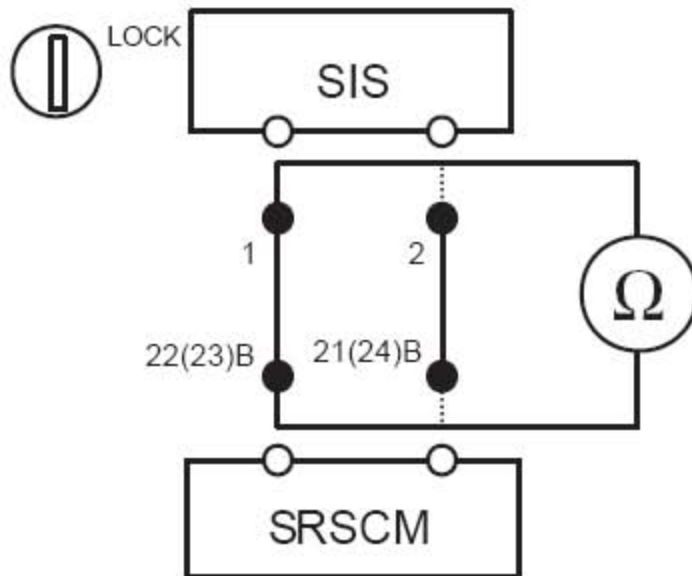

C) Is the measured resistance within specification?

YES

- ▶ Check Side Impact Sensor.

NO

- ▶ Repair or replace the wiring harness between the SIS and the SRSCM.

3). CHECK THE SIDE IMPACT SENSOR

- A) Replace the Side Impact Sensor(SIS) with a new one.
Refer to "Side Impact Sensor(SIS)" section in this SERVICE MANUAL.
- B) Install the DAB module and connect the DAB connector.
- C) Connect the connectors of the PAB, SAB, CAB, BPT, FIS and SIS.
- D) Connect the SRSCM connector.
- E) Connect the battery negative cable to the battery.
- F) Connect a Hi-Scan(Pro) to the data link connector.

G) Turn the ignition switch to ON and check the vehicle again.
Does Hi-Scan (Pro) indicate any DTC related to Side Impact Sensor(SIS)?

YES

- ▶ Go to next step.

NO

- ▶ Replace SIS.

4). CLEAR THE DTC AND CHECK THE VEHICLE AGAIN

Refer to the DESCRIPTION in this TROUBLESHOOTING section.