

B1402 、 B1405 SIDE IMPACT SENSOR

DTC DESCRIPTION

The detecting system for side crash consists of the SRSCM and four Side Impact Sensors (SIS). The SRSCM sets above DTC(s) if it detects short to battery line on the SIS circuit.

DTC	FAULT DESCRIPTION
B1401	SIDE IMPACT SENSOR [FRONT-DRIVER] CIRCUIT SHORT TO BATTERY
B1404	SIDE IMPACT SENSOR [FRONT-PASSENGER] CIRCUIT SHORT TO BATTERY

DTC DETECTING CONDITION

DTC	Condition	Probable cause
B1402 B1405	<ul style="list-style-type: none"> • Short to battery line between SIS and SRSCM • Side Impact Sensor (SIS) Malfunction • SRSCM Malfunction 	<ul style="list-style-type: none"> • Short to battery line circuit on wiring harness • Side Impact Sensor (SIS) • SRSCM

SCHEMATIC DIAGRAM

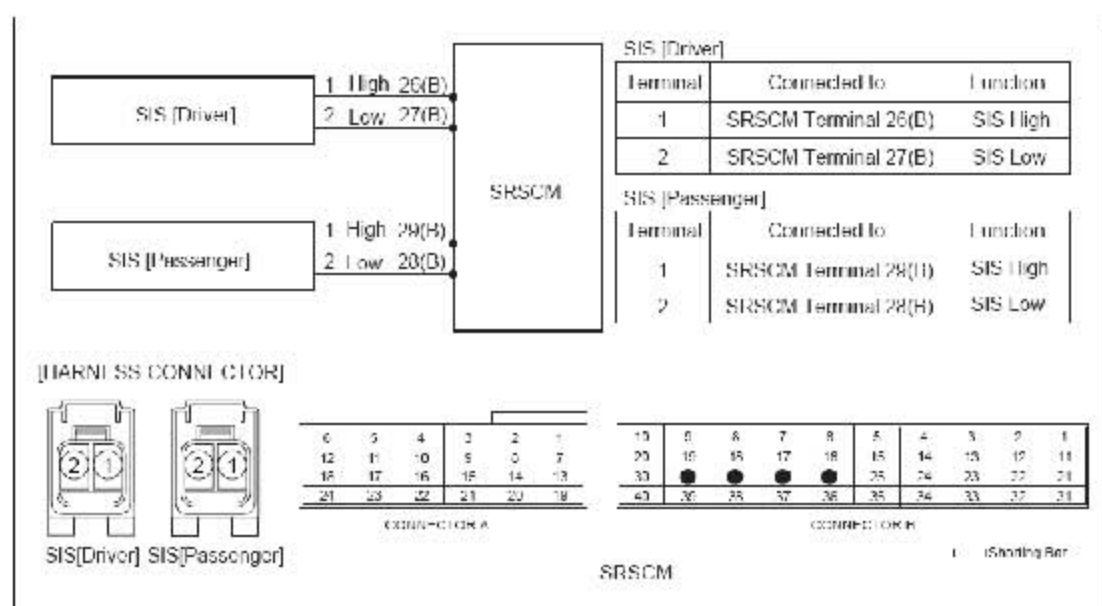

TERMINAL & CONNECTOR INSPECTION

Refer to the DESCRIPTION in this TROUBLESHOOTING section.

INSPECTION PROCEDURE

1). PREPARATION.

Refer to the DESCRIPTION in this TROUBLESHOOTING section.

2). CHECK SHORT TO BATTERY LINE

A) Connect the battery negative cable to the battery.

B) Turn the ignition switch to ON.

C) Measure voltage between the terminal 1 of SIS harness connector and chassis ground.

Specification(voltage) : Approximately 0V

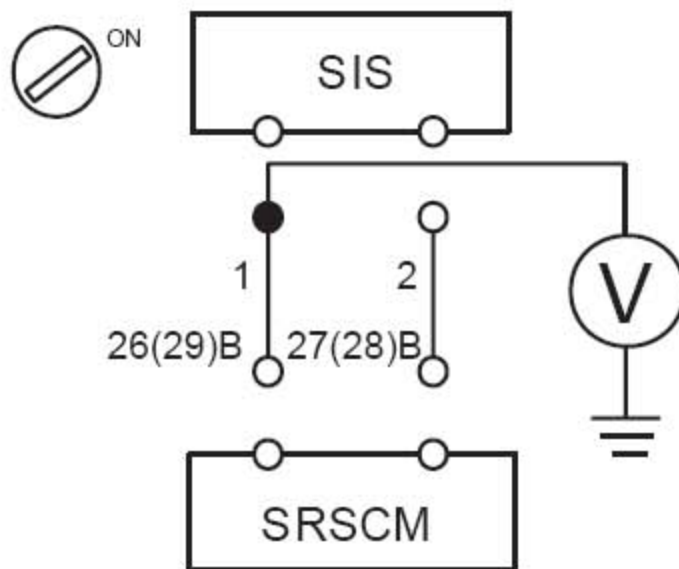

D) Is the measured voltage within specification?

YES

▶ Check the SIS Module.

NO

▶ Repair the short to battery line circuit on wiring harness between the SIS and the SRSCM.

3). CHECK THE SIS MODULE

A) Replace the Side Impact Sensor(SIS) with a new one.

Refer to "Side Impact Sensor(SIS)" section in this SERVICE MANUAL.

B) Install the DAB module and connect the DAB connector.

C) Connect the connectors of the PAB, SAB, CAB, BPT, FIS and SIS.

D) Connect the SRSCM connector.

E) Connect the battery negative cable to the battery.

F) Connect a Hi-Scan(Pro) to the data link connector.

G) Turn the ignition switch to ON and check the vehicle again.

Does Hi-Scan (Pro) indicate any DTC related to Side Impact Sensor(SIS)?

YES

▶ Go to next step.

NO

▶ Replace SIS module.

4). CLEAR THE DTC AND CHECK THE VEHICLE AGAIN

Refer to the DESCRIPTION in this TROUBLESHOOTING section.