

B1529、 B1530 PASSENGER AIRBAG

DTC DESCRIPTION

The deactivation system for the passenger airbag consists of the SRSCM and the Passenger Airbag Deactivation(PAD) switch. The above DTC is recorded when PAD switch open or short to battery is detected in the PAD circuit.

DTC	FAULT DESCRIPTION
B1529	PASSENGER AIRBAG DEACTIVATION SWITCH DEFECT
B1530	PASSENGER AIRBAG DEACTIVATION SWITCH INSTABILITY

DTC DETECTING CONDITION

DTC	Condition	Probable cause
B1529 B1530	<ul style="list-style-type: none"> • PAD switch malfunction • SRSCM malfunction 	<ul style="list-style-type: none"> • PAD switch • Wiring harness • SRSCM

SCHEMATIC DIAGRAM

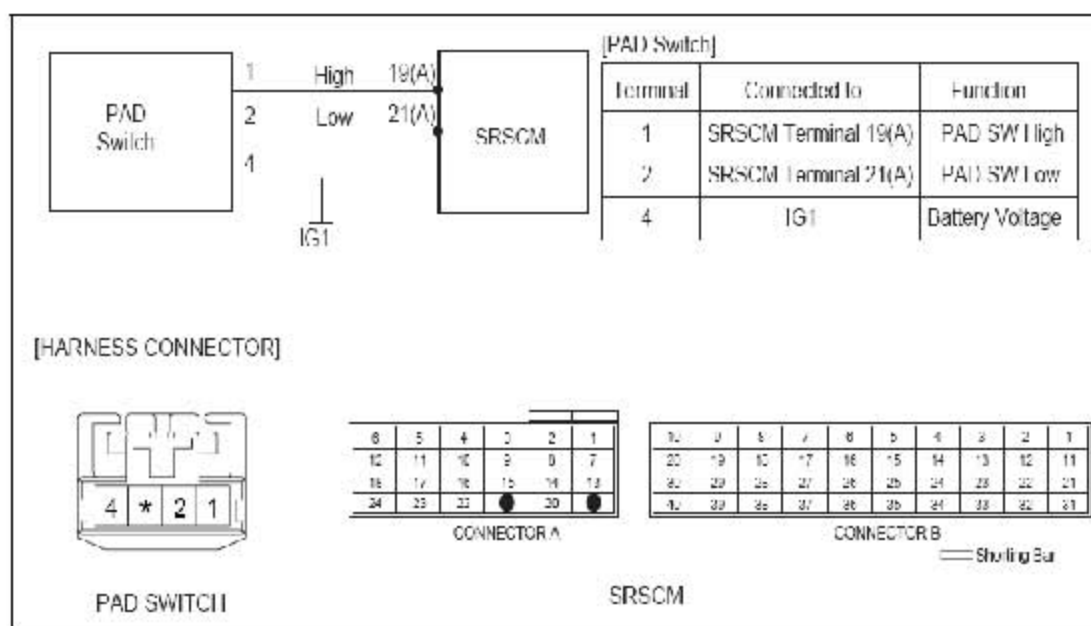

SPECIFICATION

PAD Switch Status	Resistance (Ω)	Related DTC
Short to Battery	$R > 1,114$	B1527
ON (PAB Enabled)	728 ~ 1,567	
Defect	502 ~ 1,024	B1529
OFF (PAB Disabled)	301 ~ 706	
Short to Ground	$R < 424$	B1528

TERMINAL & CONNECTOR INSPECTION

Refer to the DESCRIPTION in this TROUBLESHOOTING section.

INSPECTION PROCEDURE

1). PREPARATION.

Refer to the DESCRIPTION in this TROUBLESHOOTING section.

2). CHECK POWER SUPPLY

A) Connect the battery negative cable to the battery.

B) Turn the ignition switch to ON.

C) Measure voltage between the terminal and 4 of PAD switch harness connector and chassis ground.

Specification (voltage) : 8.38 ~ 17.0 V

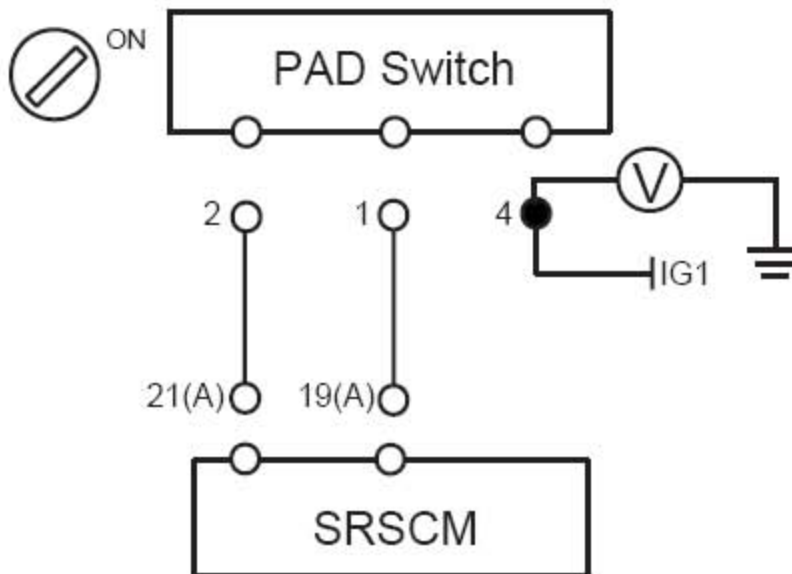

D) Is the measured voltage within specification?

YES

- ▶ Check ground circuit.

NO

- ▶ Replace the harness between the battery line and the PAD switch.

3). CHECK GROUND CIRCUIT

- A) Turn the ignition switch to OFF.
- B) Disconnect the battery negative cable from the battery.
- C) Disconnect the connector of the PAD switch.
- D) Measure resistance between the terminal 2 of PAD switch harness connector and chassis ground.

Specification (resistance) : 0 Ω

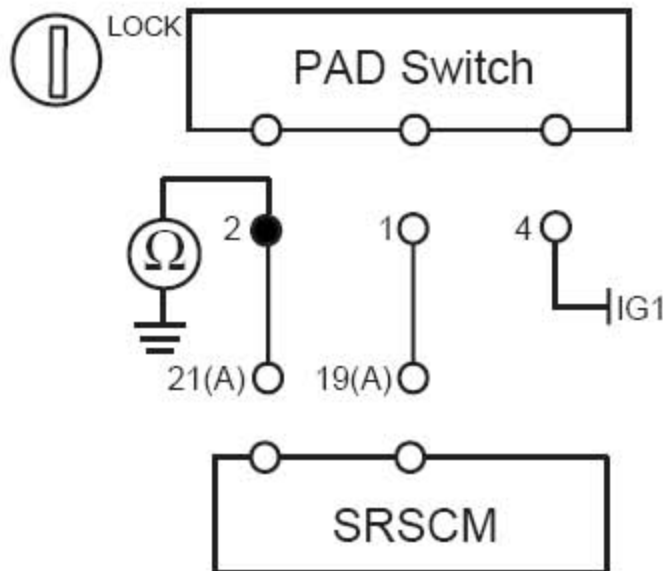

E) Is the measured resistance within specification?

YES

- ▶ Go to next step.

NO

- ▶ Repair or replace the wiring harness between the PAD switch and the chassis ground.

4). CHECK THE PAD SWITCH

- A) Connect the SRSCM connector.
- B) Connect the PAD switch.
- C) Connect the battery negative cable to the battery.
- D) Turn the ignition switch to ON.

- E) Measure resistance between the terminal 19 of the SRSCM harness connector(A) and 1 of PAD switch harness connector.

Specification (resistance :

PAD switch ON (Enabled position) : 728 ~ 1,567 Ω

PAD switch OFF (Disabled position) : 301 ~ 706 Ω

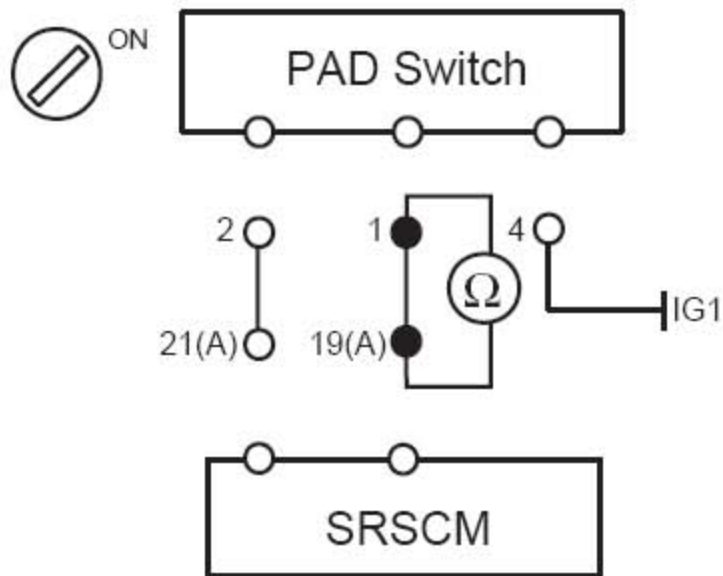

- F) Is the measured resistance within specification?

YES

- ▶ Go to next step.

NO

- ▶ Replace the PAD switch.

5). CLEAR THE DTC AND CHECK THE VEHICLE AGAIN

Refer to the DESCRIPTION in this TROUBLESHOOTING section.