

P1696 AUTHENTICATION FAIL

COMPONENT LOCATION

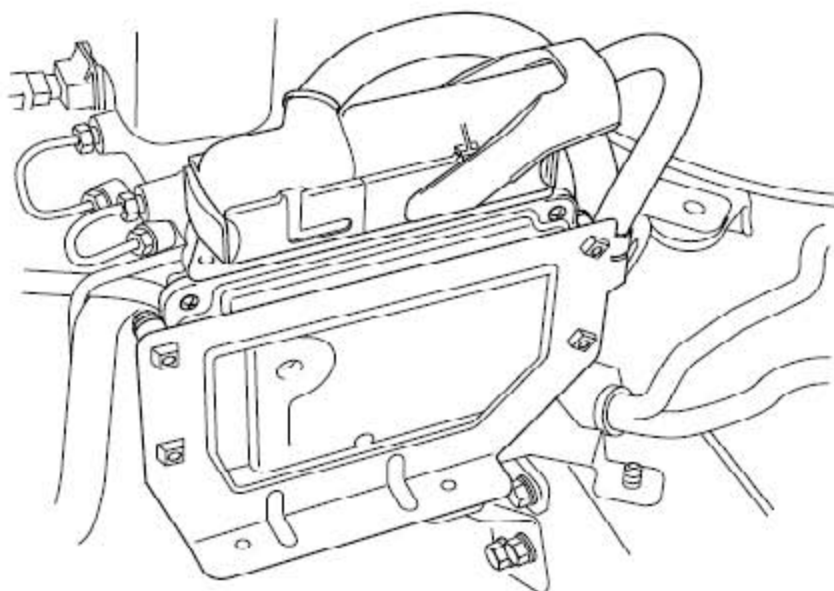

GENERAL DESCRIPTION

The ECM and the SMARTRA communicate by dedicated line. During this communication of ECM and SMARTRA the K line of ECM cannot be used for communication. The ECM controls the communication either to SMARTRA or to other devices (e.g. scanner) on K line by switching of a multiplexer and specific communication procedures. The multiplexer is a part of ECM HW.

DTC DESCRIPTION

The ECM sets DTC P1696 if invalid key is inserted into key hole for Authentication.

DTC DETECTING CONDITION

Item	Detecting Condition	Possible cause
DTC Strategy		<ul style="list-style-type: none"> • Virgin TP at EMS status "Learnt" • Learnt(Invalid) TP at EMS status "Learnt"
Enable Conditions	• IG ON	
Threshold value		
Diagnostic Time		
Fail Safe		

SCHEMATIC DIAGRAM

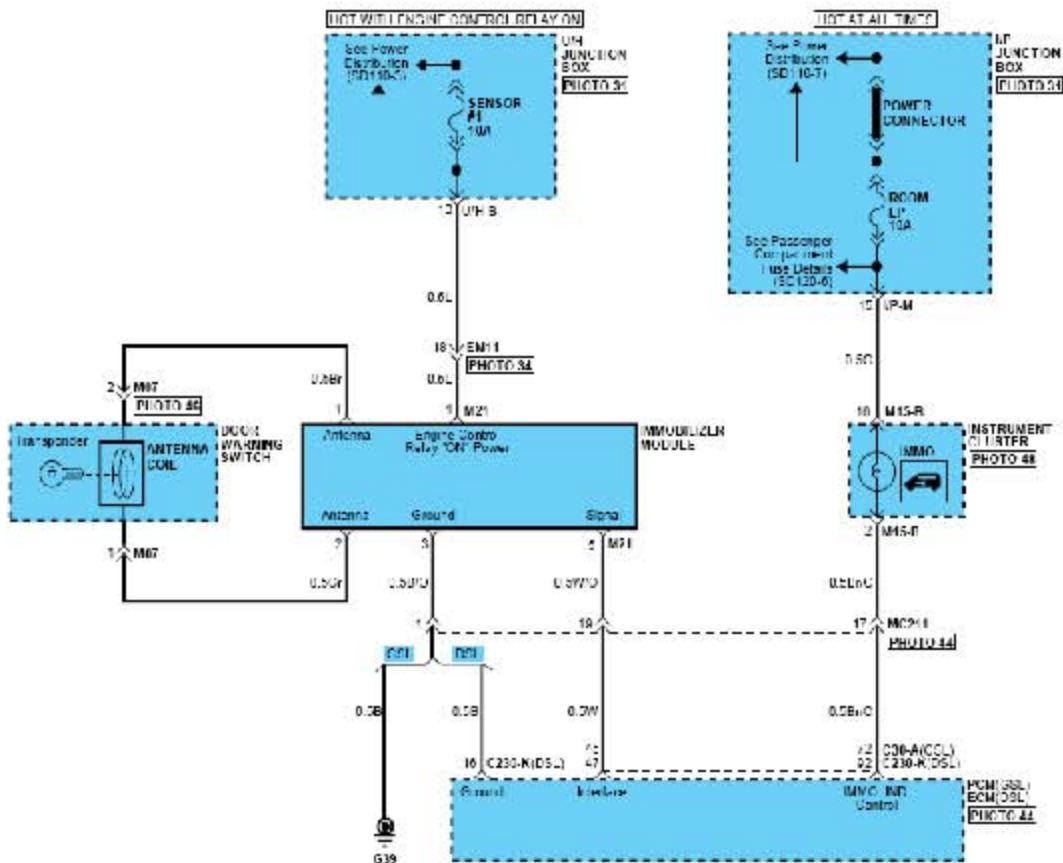
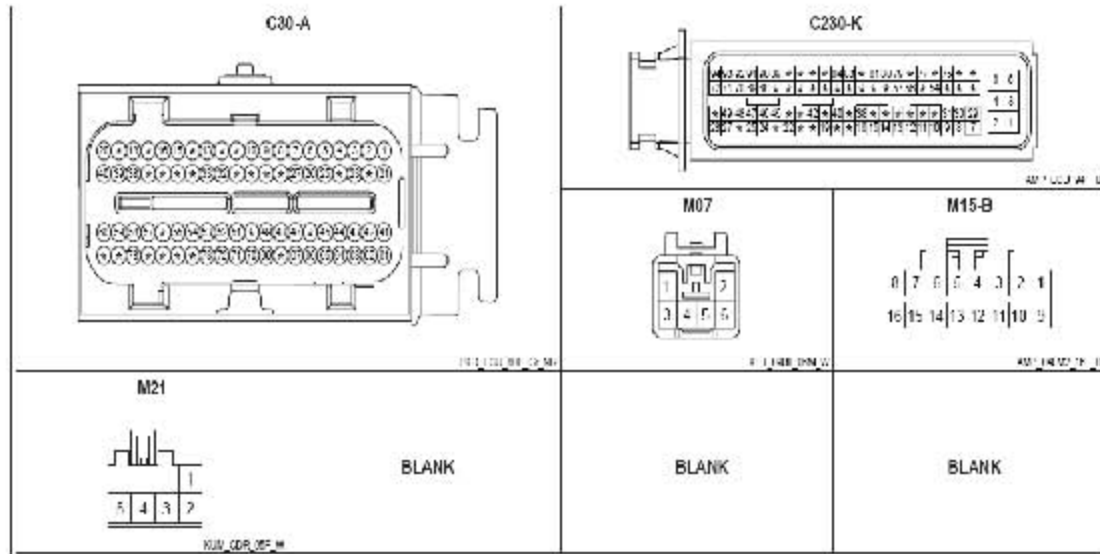

COMPONENT INSPECTION

- 1). Check transponder and ECU status
 - A) IGN "ON" & Engine "OFF".
 - B) Monitor the "KEY STATUS" and "ECU STATUS" Parameter on the Scantool.

Specification : 'LEARNT'

1.1 CURRENT DATA	
01. NO. OF LEARNT KEY	1
02. ECU STATUS	LEARNT
03. KEY STATUS	LEARNT
<div style="display: flex; justify-content: space-around; width: 100%;"> FIX SCRN FULL PART GRPH HELP </div>	

Fig 1

Fig 1) The current data in abnormal state

- C) Are "KEY STATUS" and "ECU STATUS" Parameter within specifications?

YES

Check connectors for looseness, poor connection, bending, corrosion, contamination, deterioration, or damage. Repair or replace as necessary and then go to "Verification of Vehicle Repair" procedure.

NO

Register as necessary and then go to "Verification of Vehicle Repair" procedure.

CASE 1. KEY STATUS "VIRGIN" : Register transponder key now inserted

CASE 2. KEY STATUS "INVAILD" : Register all transponder key

VERIFICATION OF VEHICLE REPAIR

After a repair, it is essential to verify that the fault has been corrected.

- 1). Connect scantool and select "Diagnostic Trouble Codes(DTCs)" mode and then clear DTC.
- 2). Operate the vehicle and monitor the DTC on the scantool.
- 3). Are any DTCs present?

YES

Go to the applicable troubleshooting procedure.

NO

System is performing to specification at this time.