

P0962: Pressure Control Solenoid Control Circuit Low

Wiring Diagram

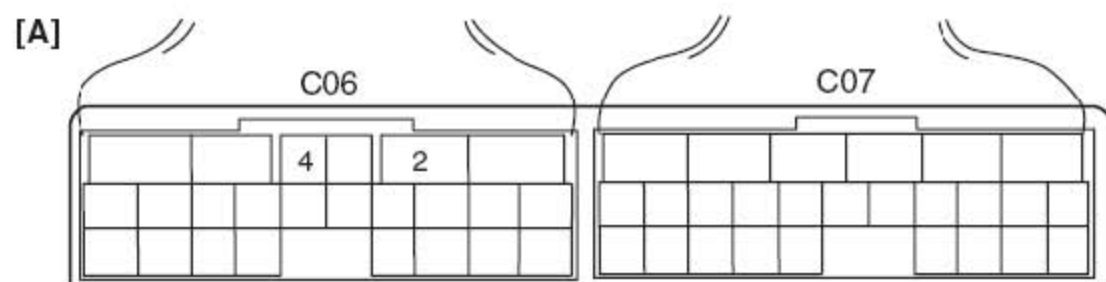
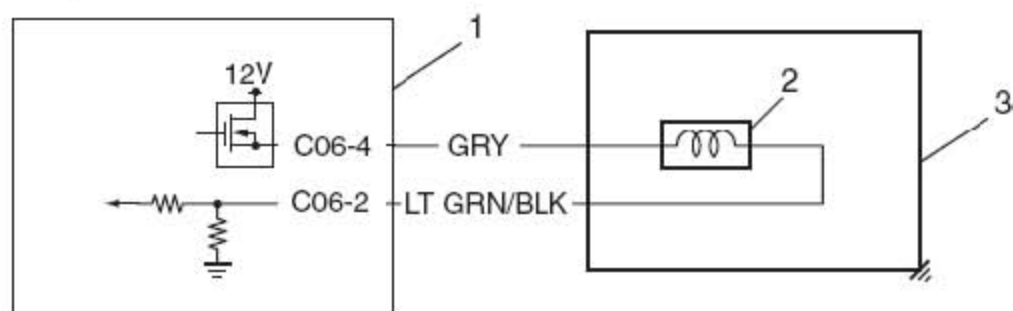

1. TCM	3. A/T
2. Pressure control solenoid valve	[A]: Terminal arrangement of TCM connector (viewed from harness side)

DTC Detecting Condition and Trouble Area

DTC detecting condition	Trouble area
Pressure control solenoid valve output voltage is too low comparing with TCM command value.	<ul style="list-style-type: none"> • Pressure control solenoid valve circuit open or shorted to ground • Malfunction of pressure control solenoid valve • TCM

DTC Confirmation Procedure

- 1) Connect scan tool to DLC with ignition switch OFF, if available.
- 2) Clear DTC in TCM memory.
- 3) Start engine.
- 4) Keep engine running at idle speed for 30 seconds or more.
- 5) Stop vehicle and check DTC.

DTC Troubleshooting

Step	Action	Yes	No
1	Was "A/T System Check" performed?	Go to Step 2.	Go to "A/T System Check".
2	<p>Check pressure control solenoid valve resistance</p> <p>1) Turn ignition switch OFF.</p> <p>2) Disconnect valve body harness connector (1), (2) on automatic transaxle.</p> <p>3) Check for proper connection to solenoid at "GRY" and "LT GRN/BLK" circuit.</p> <p>4) Check resistance of pressure control solenoid.</p> <p>Pressure control solenoid valve resistance</p> <p>Between terminals of transaxle side valve body harness connector: 5.0 – 5.6 Ω at 20 °C (68 °F)</p> <p>Between terminals of transaxle side valve body harness connector and Transaxle: Infinity</p> <p><i>Is check results satisfactory?</i></p>	Go to Step 3.	Replace pressure control solenoid valve or valve body harness.

Step	Action	Yes	No
3	<p>Check pressure control solenoid valve circuit for ground short</p> <p>1) Connect valve body harness connector.</p> <p>2) Disconnect TCM connectors.</p> <p>3) Check for proper connection to TCM at terminals "C06-2" and "C06-4". If connection is OK, check continuity between terminal "C06-4" of disconnected harness side TCM connector and ground. Is continuity indicated?</p>	<p>"GRY" or "LT GRN/BLK" circuit shorted to ground.</p>	<p>Go to Step 4.</p>
4	<p>Check pressure control solenoid valve circuit for open</p> <p>1) Check resistance continuity between terminals "C06-2" and "C06-4" of disconnected harness side TCM connector. Is it infinite?</p>	<p>"GRY" or "LT GRN/BLK" circuit open.</p>	<p>Intermittent trouble or faulty TCM. Check for intermittent referring to "Intermittent and Poor Connection Inspection in Section 00". If OK, substitute a known-good TCM and recheck.</p>