

# B1633 LEFT HI BEAM CONTROL CIRCUIT LOW

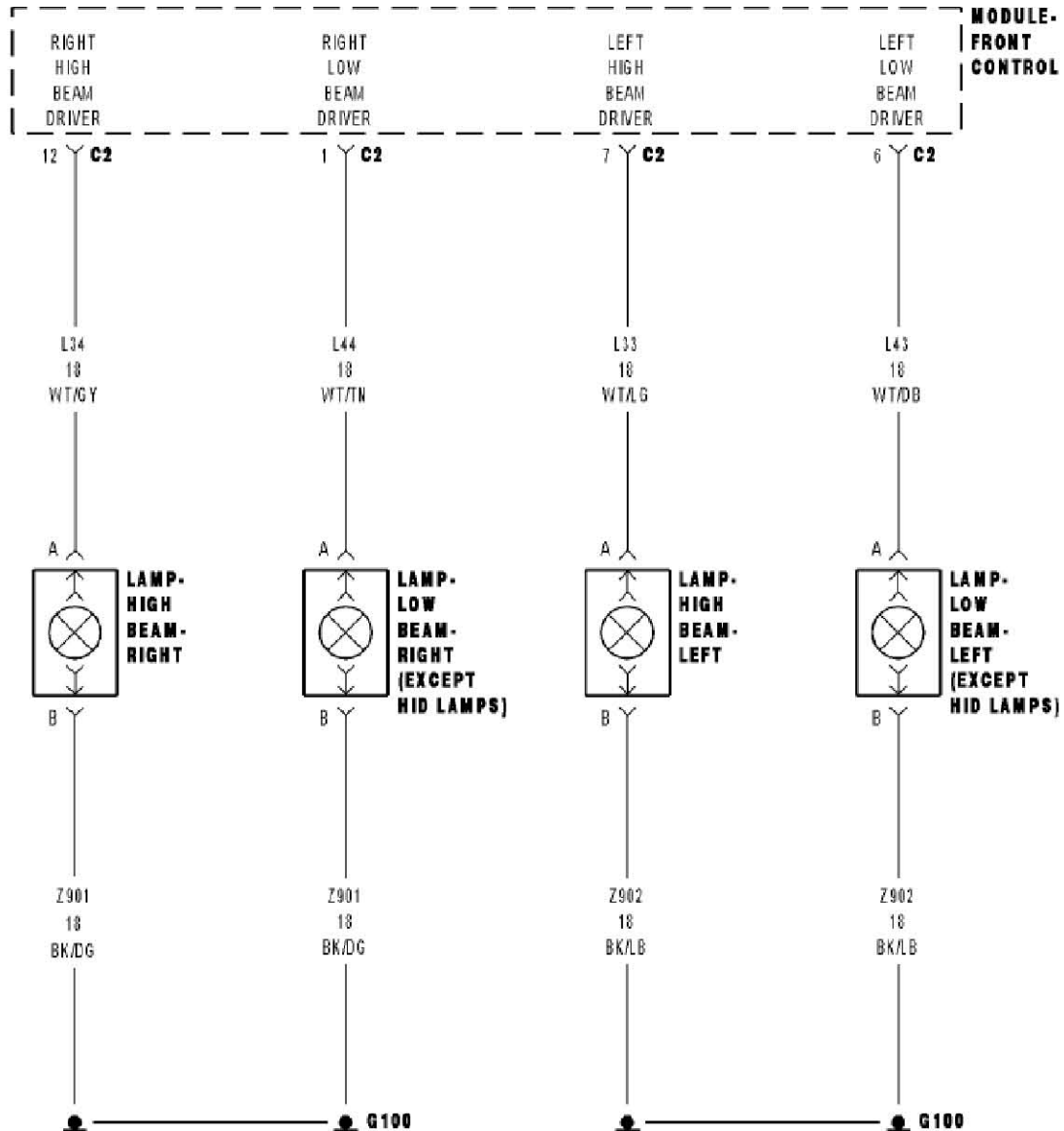

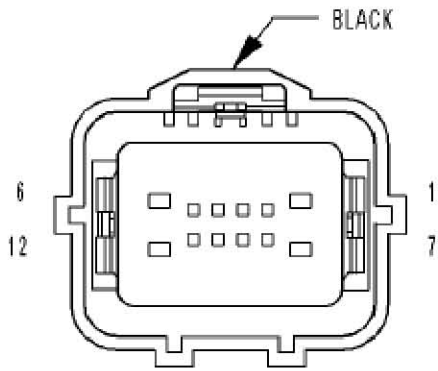

**MODULE-  
FRONT  
CONTROL C2**

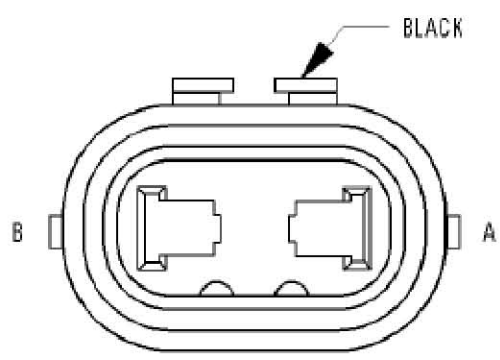

**LAMP-  
HIGH BEAM-  
LEFT**

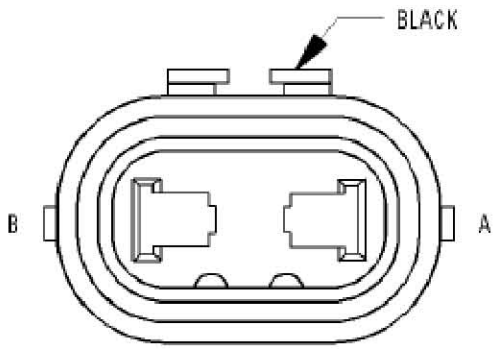

**LAMP-  
HIGH BEAM-  
RIGHT**

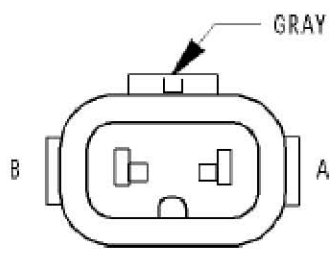

**LAMP-LOW  
BEAM-  
LEFT  
(EXCEPT HID LAMPS)**

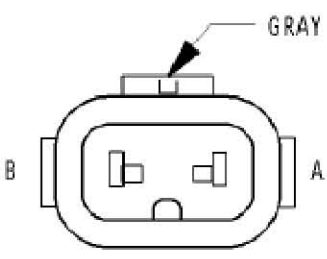

**LAMP-LOW  
BEAM-  
RIGHT  
(EXCEPT HID LAMPS)**

- 1). When Monitored:  
With the Headlamps activated.
- 2). Set Condition:  
When the FCM detects a LOW condition.

Possible Causes
1. (L33) LEFT HIGHBEAM OUTPUT CIRCUIT
2. FRONT CONTROL MODULE



## Diagnostic Test

### 1). INTERMITTENT CONDITION

- Turn the ignition on.
- With the Scan Tool, clear all FCM DTC's.
- Turn the Highbeam Headlamps on.
- With the Scan Tool read the DTC information.

Does the Scan Tool read: B1633-LEFT HI BEAM CONTROL CIRCUIT LOW?

**Yes** >> Go To 2

**No** >> The condition that caused the symptom is currently not present. Inspect the related wiring for a possible intermittent condition. Look for any chafed, pierced, pinched, or partially broken wires.  
Perform the BODY VERIFICATION TEST - VER 1.

### 2). (L33) LEFT HIGHBEAM OUTPUT CIRCUIT

- Turn the ignition off.
- Disconnect the FCM C2 harness connector.
- Measure the resistance between ground and the Left Highbeam Output circuit.

Is the resistance below 5.0 ohms?

**Yes** >> Replace the Front Control Module (FCM) in accordance with the service information.

Perform the BODY VERIFICATION TEST - VER 1.

**No** >> Repair the (L33) Left Highbeam Output circuit for a short to ground condition.

Perform the BODY VERIFICATION TEST - VER 1.

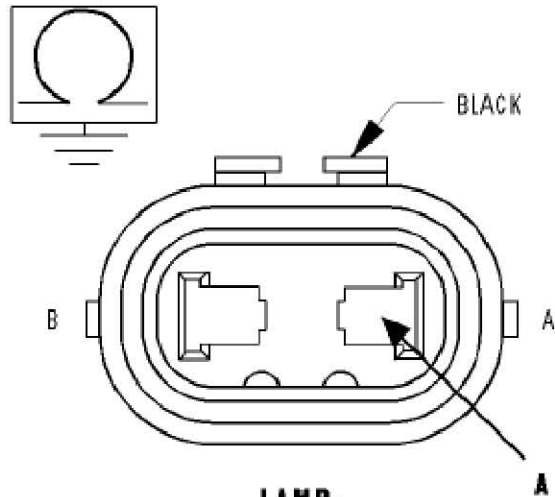

**LAMP-  
HIGH BEAM-  
LEFT**

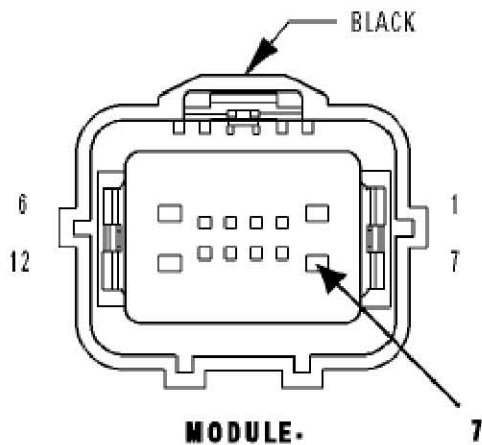

**MODULE-  
FRONT  
CONTROL C2**