

Wireless Door Lock Control

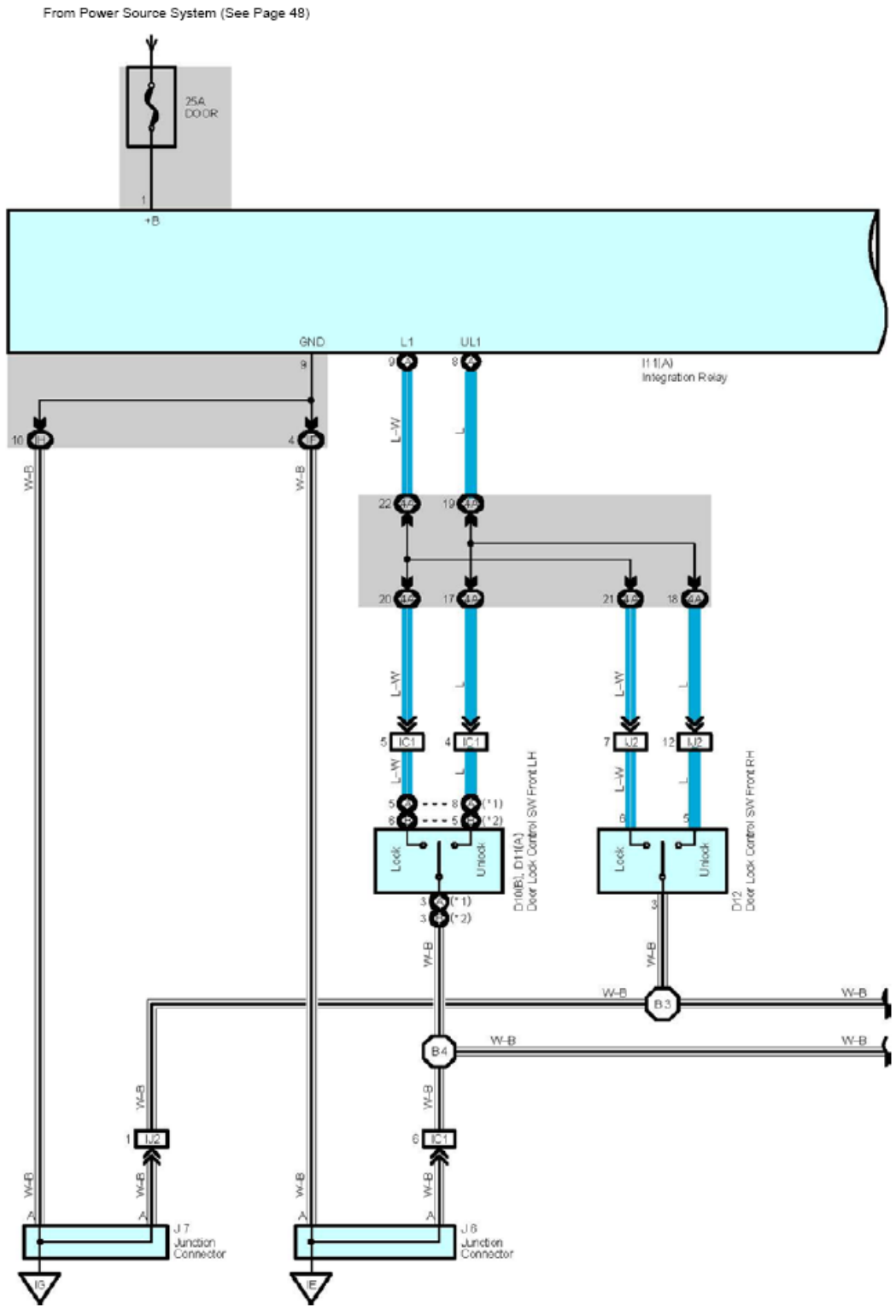

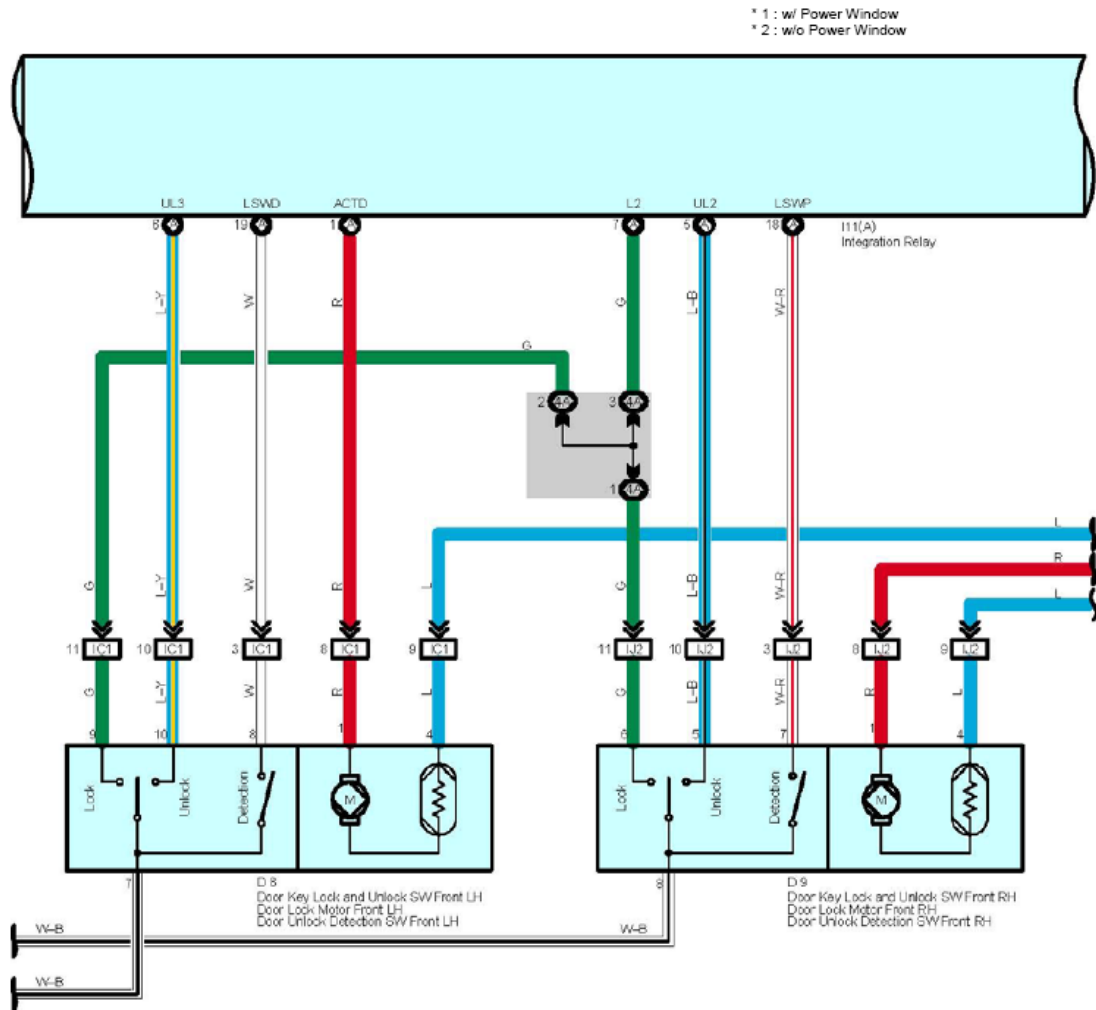

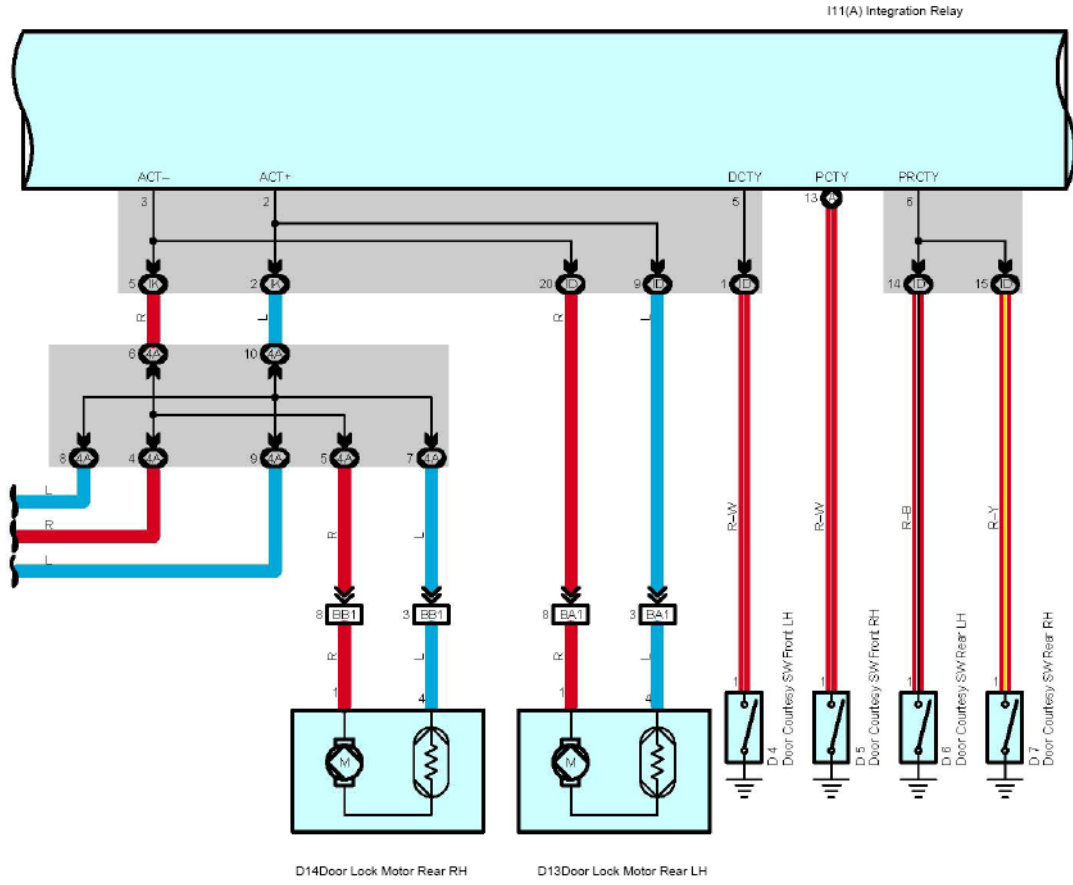

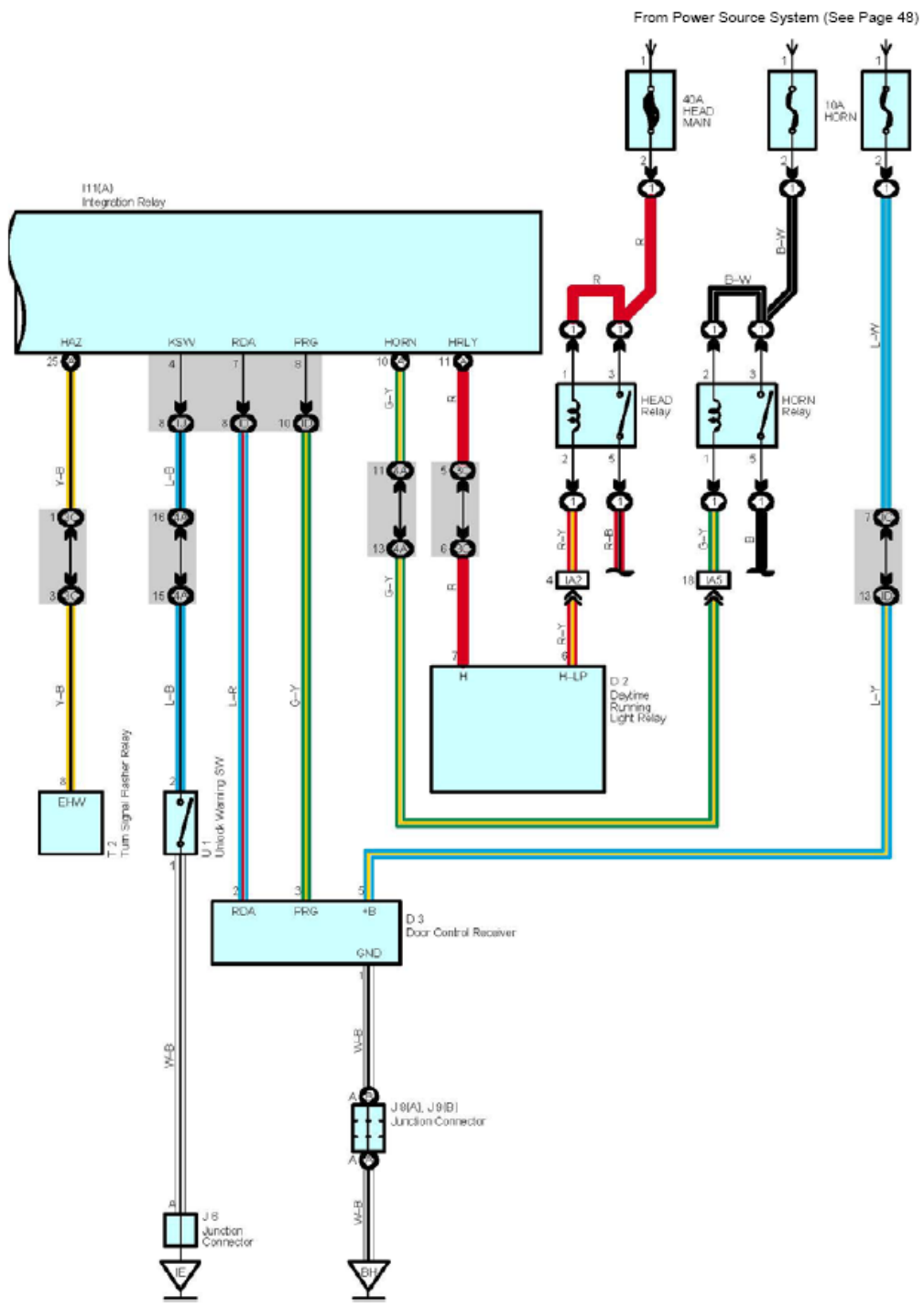

System Outline

Door lock control (Lock and unlock) and panic control (TVIP alarm and flash) is performed by remote control, without the ignition key inserted in the door key cylinder, using low-power electrical waves emitted by a transmitter.

1. Wireless Door Lock or Unlock Normal Operation

With the ignition key not inserted into the ignition key cylinder (Unlock warning SW off) and all the doors completely closed, when the lock or unlock button (Transmitter) is pushed, the door control receiver receives the electrical waves from the transmitter, and sends a signal to the integration relay causing it to operate.

As a result, the integration relay judges whether the door is locked or unlocked based on the signal from the door lock motor and door unlock detection SW, and sends a signal to switch the condition from lock to unlock or vice versa, causing the door lock motor to operate.

2. Visual Confirmation of Lock or Unlock

If all doors indicate that they are locked after the lock command, parking lights and taillights will flash once. If any door indicates that it is open after the unlock command, parking lights and taillights will flash twice.

3. Wireless Door Unlock Operation

Pushing the unlock button (Transmitter) once, driver's door is unlocked. Furthermore, pushing the button again within 3 seconds, the other doors are unlocked.

4. Automatic Lock Operation

With the ignition key not inserted into the ignition key cylinder (Unlock warning SW off) and all the doors completely closed, after pushing the button (Transmitter) to unlock all the doors, if a door is not opened within 30 seconds, all the doors will be automatically relocked.

5. Wireless Control Stop Function

If a door is open (Door courtesy SW on), a signal is input from the door courtesy SW to the integration relay stopping wireless door lock or unlock.

If the ignition key is in the ignition key cylinder (Unlock warning SW on), the unlock warning SW inputs a signal to the integration relay stopping wireless door lock or unlock.

6. Repeat Function

In case an appropriate lock detection signal is not received after outputting a lock signal when pushing the lock button (Transmitter), 1 seconds later, the integration relay output the lock signal again.

7. Remote Panic Operation

Panic will function when doors are locked or unlocked, open or closed. When the panic button (Transmitter) is pushed once, theft alarm sounds and headlights and taillights flash. Then, the panic or the unlock button (Transmitter) is pushed once more, sounding and flashing will stop. Panic will not function when ignition key is in ignition key cylinder.

Service Hints**I11 (A) Integration Relay**

9-Ground : Always continuity

5-Ground : Continuity with the driver's door open

1-Ground : Always approx. 12 volts

2-Ground : Approx. 12 volts 0.2 seconds with following operation

Door lock control SW locked

Locking the driver's, front passenger's door cylinder with the key

(A) 9-Ground : Continuity with the door lock control SW locked

(A) 13-Ground : Continuity with the front passenger's door open

(A) 19-Ground : Continuity with the driver's door lock knob unlocked

(A) 8-Ground : Continuity with the door lock control SW unlocked

(A) 5-Ground : Continuity with the front passenger's door lock cylinder unlock with the key

(A) 6-Ground : Continuity with the driver's door lock cylinder unlocked with the key

(A) 7-Ground : Continuity with the driver's, front passenger's door lock cylinder locked with the key

(A) 1 or 3-Ground : Approx. 12 volts 0.2 seconds with following operation

Door lock control SW unlocked

Door lock control SW locked with the ignition key in cylinder and the driver's door open (Ignition key reminder function)

Door lock knob locked with the ignition key in cylinder and the driver's door open (Ignition key reminder function)

Unlocking the driver's, front passenger's door cylinder with the key

D4, D5, D6, D7 Door Courtesy SW Front LH, RH, Rear LH, RH

1-Ground : Closed with the door open

U1 Unlock Warning SW

1-2 : Closed with the ignition key in cylinder

D3 Door Control Receiver

5-Ground : Always approx. 12 volts

1-Ground : Always continuity

Relay Blocks

Code	Relay Blocks (Relay Block Location)
1	Engine Room R/B (Engine Compartment Left)

Junction Block and Wire Harness Connector

Code	Junction Block and Wire Harness (Connector Location)
IC	Engine Room Main Wire and Instrument Panel J/B (Lower Finish Panel)
ID	Floor Wire and Instrument Panel J/B (Lower Finish Panel)
IF	Instrument Panel Wire and Instrument Panel J/B (Lower Finish Panel) Instrument Panel Wire and Instrument Panel J/B (Lower Finish Panel)
IH _	
IJ _	
IK	
3C	Instrument Panel Wire and RH J/B (Right Side of the Instrument Panel Reinforcement)
4A	Instrument Panel Wire and Center J/B (Behind the Combination Meter)

Connector Joining Wire Harness and Wire Harness

Code	Joining Wire Harness and Wire Harness (Connector Location)
IA2	Engine Room Main Wire and Instrument Panel Wire (Left Side of the Instrument Panel Reinforcement) Engine Room Main Wire and Instrument Panel Wire (Left Side of the Instrument Panel Reinforcement)
IA5 _	
IC1	Front Door LH Wire and Instrument Panel Wire (Left Kick Panel)
IJ2	Front Door RH Wire and Instrument Panel Wire (Right Kick Panel)
BA1	Rear Door LH Wire and Floor Wire (Left Center Pillar)
BB1	Rear Door RH Wire and Instrument Panel Wire (Right Center Pillar)

Ground Points

Code	Ground Points Location
IE	Behind the Combination Meter
IG	Right Kick Panel
BH	Under the Left Quarter Pillar

Splice Points

Code	Wire Harness with Splice Points	Code	See Page	Wire Harness with Splice Points
B3	Front Door RH Wire	B4	44	Front Door LH Wire