

Door Lock Control

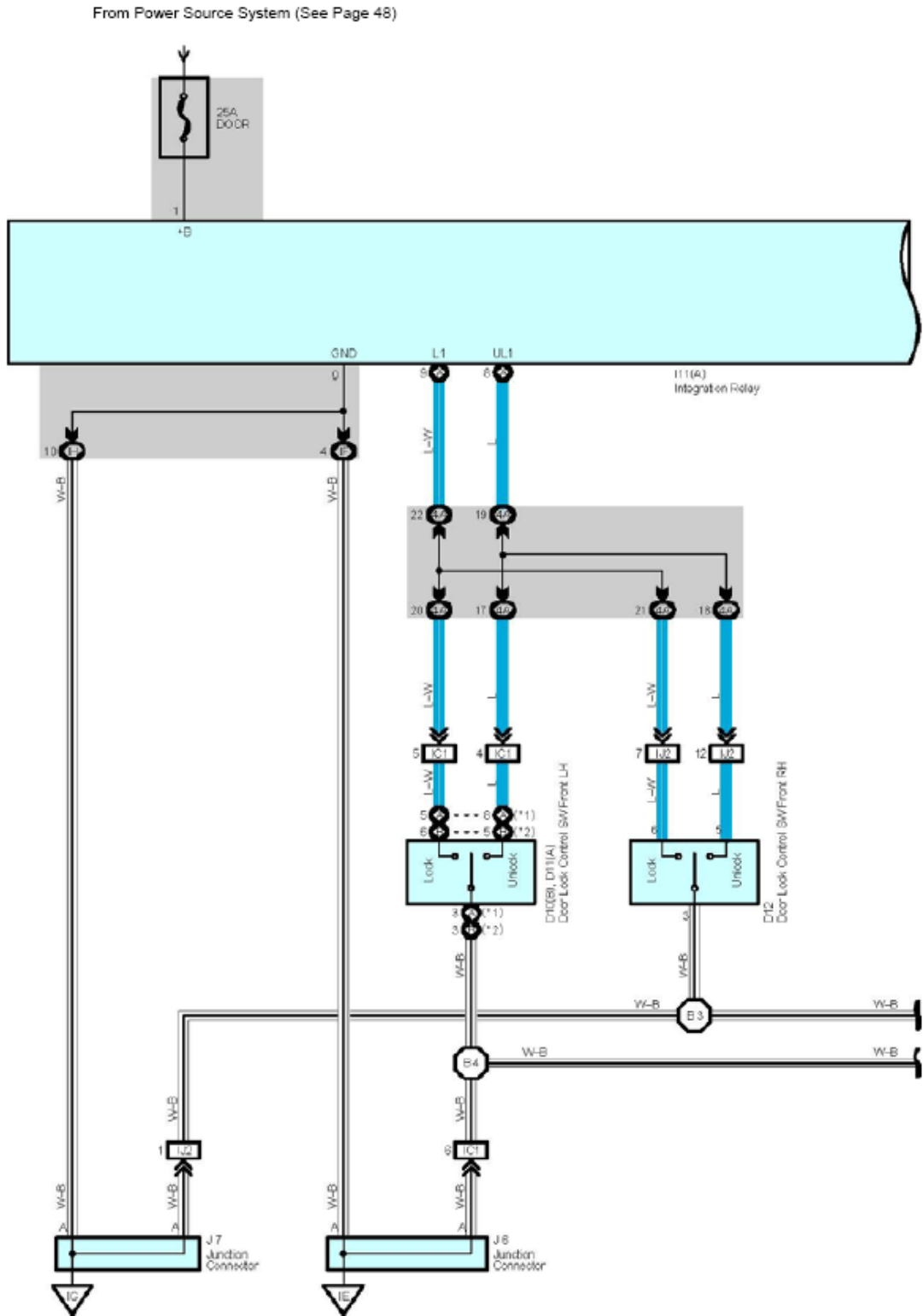

* 1 : w/ Power Window
* 2 : w/o Power Window

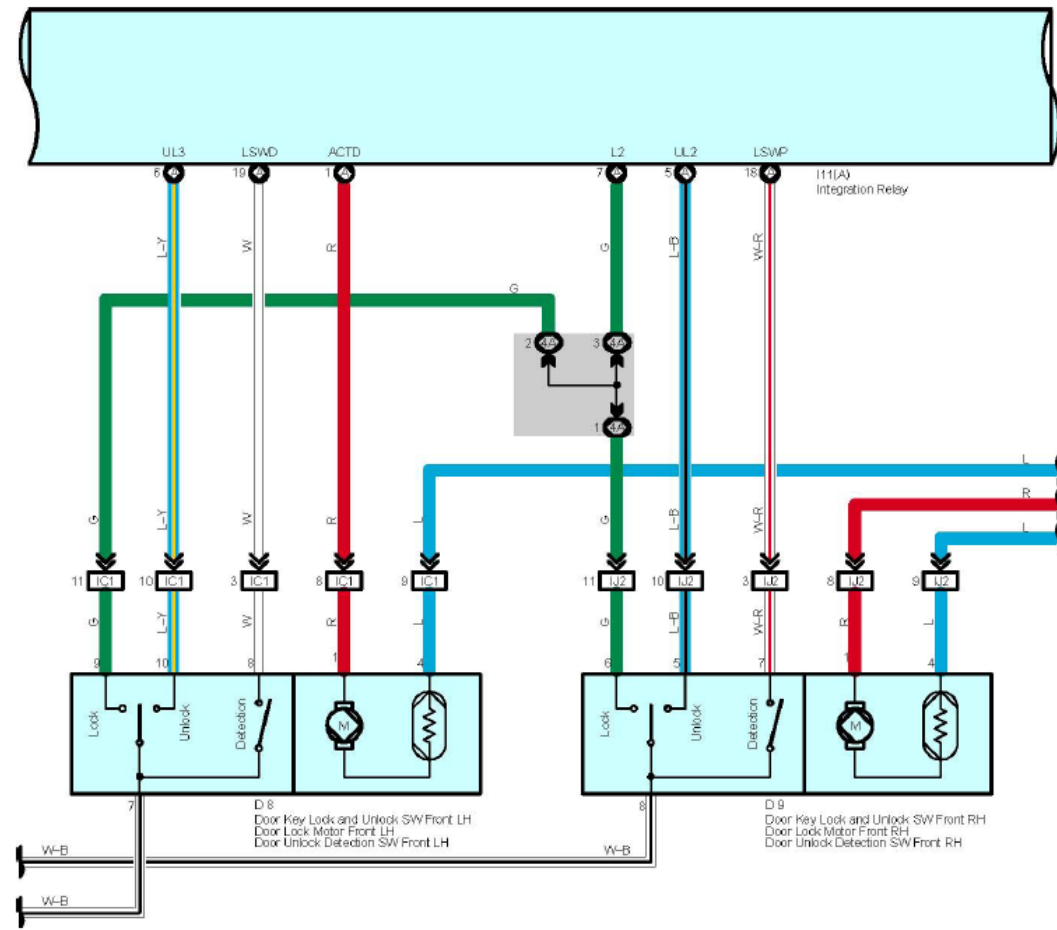

Door Lock Control

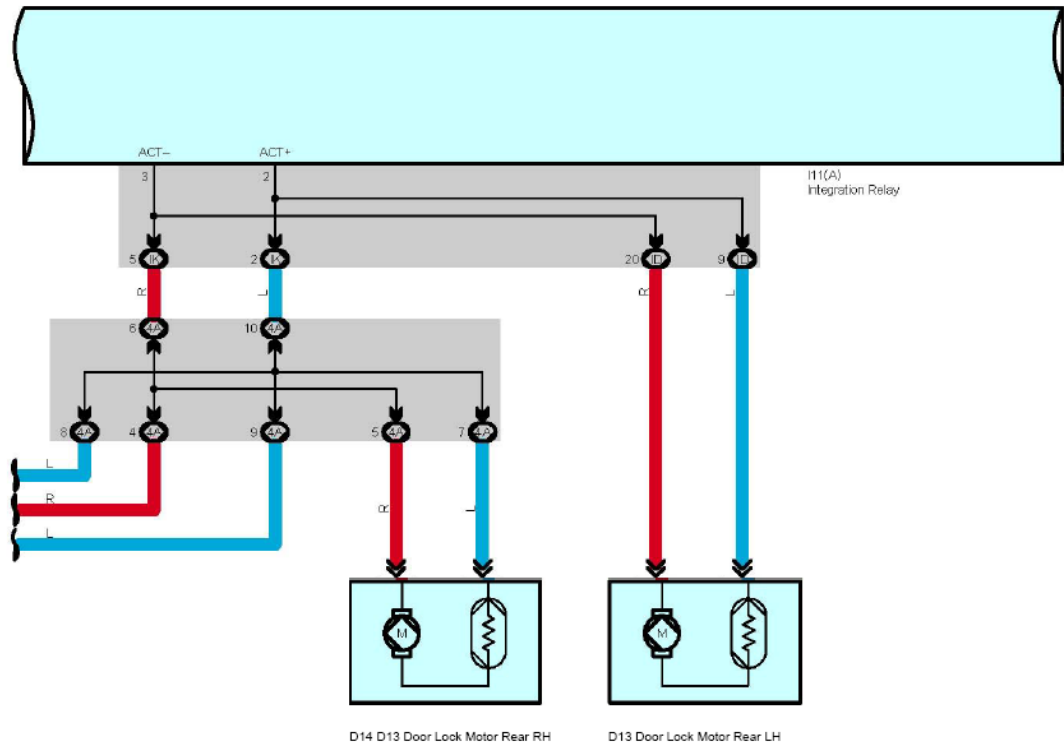

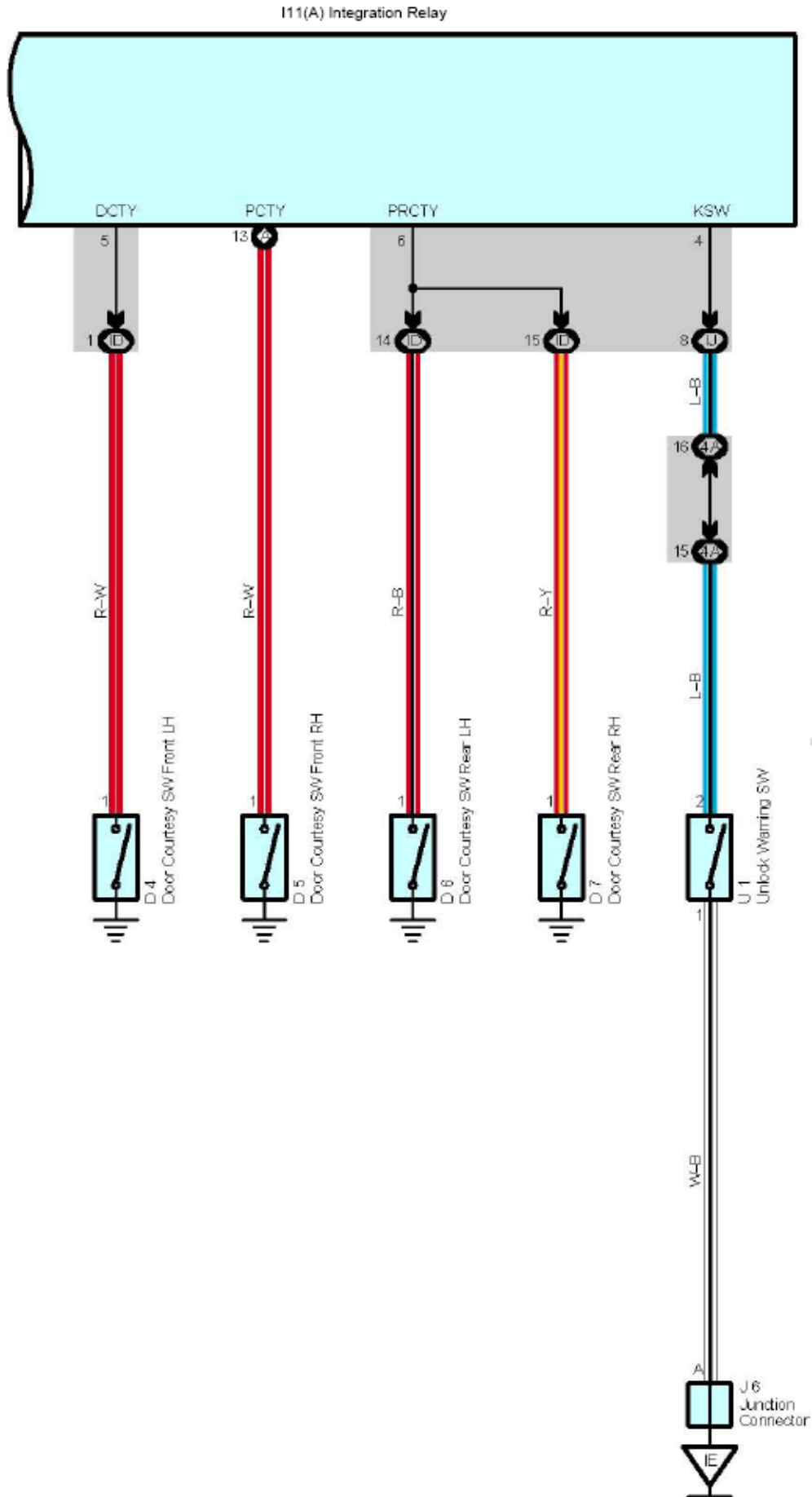

Door Lock Control

System Outline The current always flows to TERMINAL 1 of the integration relay through the DOOR fuse.

1. Manual Lock Operation

When the door lock control SW or door key lock and unlock SW are operated to Lock position, a lock signal is input to TERMINAL (A) 9 or (A) 7 of the integration relay and causes the relay to function. The current flows from TERMINAL 1 of the relay to TERMINAL 2 to the door lock motors to TERMINALS (A) 1 and 3 of the relay to TERMINAL 9 to GROUND and the door lock motors locks the door.

2. Manual Unlock Operation

When the door lock control SW or door key lock and unlock SW are operated to Unlock position, an unlock signal is input to TERMINAL (A) 8, (A) 6 or (A) 5 of the integration relay and causes the relay to function. The current flows from TERMINAL 1 of the relay to TERMINALS (A) 1 and 3 to the door lock motors to TERMINAL 2 of the relay to TERMINAL 9 to GROUND and the door lock motors unlocks the door.

3. Double Operation Unlock Operation

When the door key lock and unlock SW LH is turned to the unlock side, only the driver's door is unlocked. By turning the door key lock and unlock SW LH to the unlock side, a signal is input to TERMINAL (A) 6 of the relay, and if the signal is input again within 3 seconds by turning the SW to the unlock side again, current flows from TERMINAL 3 of the integration relay to the door lock motors to TERMINAL 2 of the relay to TERMINAL 9 to GROUND, causing the door lock motors to operate and unlock the doors.

4. Ignition Key Reminder Operation

Operating door lock knob (Operation of door lock motors)

With the ignition key in the cylinder (Unlock warning SW on), when the door is opened and locked using door lock knob (Door lock motor), the door is locked once but each door is unlocked soon by the function of the relay. As a result, the current flows from TERMINAL 1 of the integration relay to TERMINALS (A) 1 and 3 to the door lock motors to TERMINAL 2 of the relay to TERMINAL 9 to GROUND and unlocks all the doors.

Operating door lock control SW or door key lock and unlock SW

With the ignition key in the cylinder (Unlock warning SW on), when the door is opened and locked using door lock control SW or key SW, the door is locked once but each door is unlocked by the function of SW contained in motors, and the signal is input to TERMINAL (A) 19 of the relay. According to this input signal, the current flows from TERMINAL 1 of the relay to TERMINALS (A) 1 and 3 to the door lock motors to TERMINAL 2 of the relay to TERMINAL 9 to GROUND and unlocks all the doors.

In case of key less lock

With the ignition key in the cylinder (Unlock warning SW on), when the unlock function is disturbed, for example pushing the door lock knob etc., the door holds on lock condition. After closing the door after, door courtesy SW inputs the signal into TERMINAL 5 or 6 or (A) 13 of the integration relay. By this input signal, the relay works and current flows from TERMINAL 1 of the relay to TERMINALS (A) 1 and 3 to the door lock motors to TERMINAL 2 of the relay to TERMINAL 9 to GROUND and unlocks all the doors.

Service Hints

I11 (A) Integration Relay

9-Ground : Always continuity

5-Ground : Continuity with the driver's door open

1-Ground : Always approx. 12 volts

2-Ground : Approx. 12 volts 0.2 seconds with following operation

Door lock control SW locked

Locking the driver's, front passenger's door cylinder with the key

A 9-Ground : Continuity with the door lock control SW locked

A13-Ground : Continuity with the front passenger's door open

A 19-Ground : Continuity with the driver's door lock knob unlocked

A 8-Ground : Continuity with the door lock control SW unlocked

A5-Ground : Continuity with the front passenger's door lock cylinder unlock with the key

A 6-Ground : Continuity with the driver's door lock cylinder unlocked with the key

A 7-Ground : Continuity with the driver's, front passenger's door lock cylinder locked with the key

A1 or 3-Ground : Approx. 12 volts 0.2 seconds with following operation

Door lock control SW unlocked

Door lock control SW locked with the ignition key in cylinder and the driver's door open (Ignition key reminder function)

Door lock knob locked with the ignition key in cylinder and the driver's door open (Ignition key reminder function)

Unlocking the driver's, front passenger's door cylinder with the key

D4, D5, D6, D7 Door Courtesy SW Front LH, RH, Rear LH, RH

1–Ground : Closed with the door open

U1 Unlock Warning SW

1–2 : Closed with the ignition key in cylinder

Connector Joining Wire Harness and Wire Harness

Code	Joining Wire Harness and Wire Harness (Connector Location)
IC1	Front Door LH Wire and Instrument Panel Wire (Left Kick Panel)
IJ2	Front Door RH Wire and Instrument Panel Wire (Right Kick Panel)
BA1	Rear Door LH Wire and Floor Wire (Left Center Pillar)
BB1	Rear Door RH Wire and Instrument Panel Wire (Right Center Pillar)

Ground Points

Code	Ground Points Location
IE	Behind the Combination Meter
IG	Right Kick Panel

Door Lock Control

Splice Points

Code	Wire Harness with Splice Points	Code	See Page	Wire Harness with Splice Points
B3	Front Door RH Wire	B4	44	Front Door LH Wire